

## CMT-555 DATASHEET

Revision: 1.2  
12-Nov-10 (Modified)

## HIGH TEMPERATURE RANGE 555 TIMER

### General Description

The CMT-555 is an extended temperature range, low-power, highly stable device for generating accurate time delays or oscillation, with enhanced capabilities compared to the well known 555 timer. It can be used as a direct replacement of the standard 555 in applications working from -55°C to +175°C or it can be used in a larger package in order to make use of the enhanced capabilities. These capabilities include the presence of a pin that provides a voltage decreasing linearly with the die temperature as well as a bank of four binary-weighted capacitors from 20pF to 160pF. Because of its high input impedance, this device allows the use of smaller capacitors than those used by the standard 555, then providing more accurate time delays and oscillations, as well as cheaper BOM. The CMT-555 can be used throughout the -55°C to +175°C temperature range.

### Features

- Supply voltage 5V +/-10%
- Low supply current
- Timing from microseconds to hours
- Operates in both monostable and astable modes
- Highly stable timing characteristics with temperature and supply voltage
- On-chip temperature sensor -1.47mV/°C
- Available in several standard packages

### Applications

- Well logging, Automotive, Aeronautics & Aerospace
- Precision timing
- Pulse generation
- Pulse width and pulse position modulation

### Available Package Options

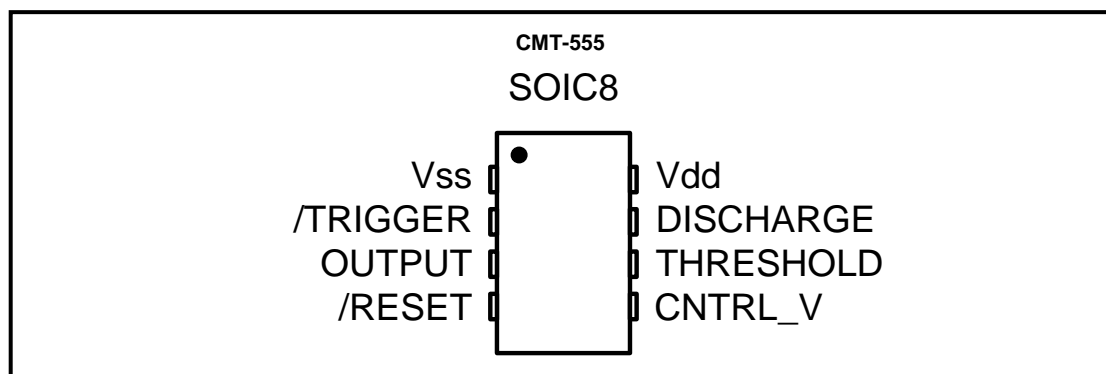

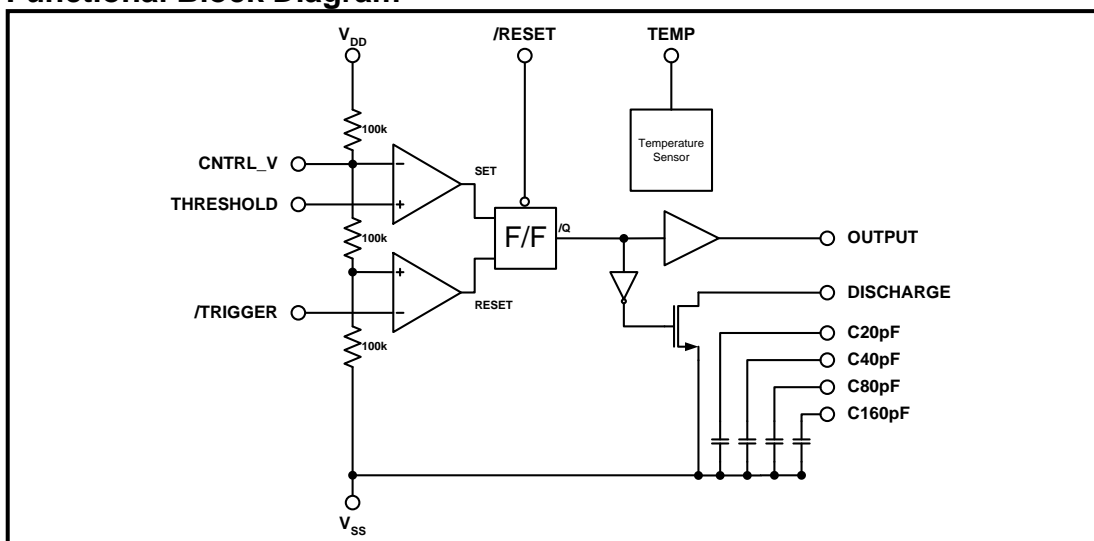
**Functional Block Diagram**

**Pin Description**

<b>C20pF</b>	Built-in, binary-weighted capacitors with a common terminal connected to V <sub>SS</sub> .	<b>TEMP</b>	Temperature sense pin. Gives a voltage that decreases with the die temperature.
<b>C40pF</b>		<b>THRESHOLD</b>	Resets the output with a rising edge.
<b>C80pF</b>		<b>/TRIGGER</b>	Sets the output with a falling edge.
<b>C160pF</b>		<b>VDD</b>	Power supply terminal.
<b>CNTR_V</b>	It can be forced to a given voltage to change the triggering thresholds.	<b>VSS</b>	Ground terminal.
<b>DISCHARGE</b>	Open drain N-type output. Active when OUTPUT = LOW.		
<b>OUTPUT</b>	Main output.		
<b>/RESET</b>	Main reset. When LOW, inhibits response from all other inputs.		

**Funtion Table**

/RESET	THRESHOLD	/TRIGGER	OUTPUT	DISCHARGE
L	X	X	L	ON
H	$> 2/3V_{DD}$	$> 1/3V_{DD}$	L	ON
H	$< 2/3V_{DD}$	$< 1/3V_{DD}$	H	OFF
H	$< 2/3V_{DD}$	$> 1/3V_{DD}$	Previous state	Previous state
H	$> 2/3V_{DD}$	$< 1/3V_{DD}$	L	ON

**Absolute Maximum Ratings**

 Supply Voltage  $V_{DD}$  to GND -0.5 to 6.0V  
 Voltage on any Pin to GND -0.5 to  $V_{DD}+0.3V$ 
**Operating Conditions**

 Supply Voltage  $V_{DD}$  to GND  $5V \pm 10\%$   
 Junction temperature  $-55^{\circ}C$  to  $+175^{\circ}C$ 
**ESD Rating (expected)**

Human Body Model 1kV

**Electrical Characteristics**

 Unless otherwise stated:  $V_{DD}=5V$ ,  $T_j=25^{\circ}C$ . **Bold underlined** values indicate values over the whole temperature range ( $-55^{\circ}C < T_j < +175^{\circ}C$ ).

Parameter	Condition	Min	Typ	Max	Units
Supply voltage		4.5		5.5	V
Current consumption	$R_L = \infty$ $V_{THRESHOLD} < 2V_{DD}/3$ $V_{THRESHOLD} > 2V_{DD}/3$		280 350	<b>360</b> <b>480</b>	$\mu A$
Timing Error: Monostable <sup>1,2</sup> (see Figure 1 and Figure 2)					
Initial accuracy	$R_a = 1k$ to $1MEG\Omega$ , $C = 10nF$		2.5 <b>3.5</b>		%
Drift with Temperature	$R_a = 1k$ to $100k\Omega$ , $C = 10nF$ $R_a = 1MEG\Omega$ , $C = 10nF$		7 <b>67</b>		ppm/ $^{\circ}C$
Drift with Supply Voltage	$R_a = 10k$ to $1MEG\Omega$ , $C = 10nF$ $R_a = 1k\Omega$ , $C = 10nF$		0.05 <b>0.2</b>		%/V
Timing Error: Astable <sup>3</sup> (see Figure 5 and Figure 6)					
Initial accuracy	$R_a, R_b = 10k$ to $1MEG\Omega$ , $C = 10nF$ $R_a, R_b = 1k\Omega$ , $C = 10nF$		3 <b>5</b>		%
Drift with Temperature	$R_a, R_b = 1k$ to $100k\Omega$ , $C = 10nF$ $R_a, R_b = 1MEG\Omega$ , $C = 10nF$		20 <b>100</b>		ppm/ $^{\circ}C$
Drift with Supply Voltage	$R_a, R_b = 10k$ to $1MEG\Omega$ , $C = 10nF$ $R_a, R_b = 1k\Omega$ , $C = 10nF$		0.2 0.3		%/V
Threshold Voltage		<b>0.660</b>	<b>0.666</b>	<b>0.670</b>	$\times V_{DD}$
Trigger Voltage		<b>0.330</b>	<b>0.335</b>	<b>0.339</b>	$\times V_{DD}$
Control Voltage		<b>0.660</b>	<b>0.667</b>	<b>0.671</b>	$\times V_{DD}$
Discharge switch on-state voltage	$I_{DISCH} = 1mA$ $T_j = 25^{\circ}C$ $T_j = 175^{\circ}C$		14	18 <b>25</b>	mV
	$I_{DISCH} = 5mA$ $T_j = 25^{\circ}C$ $T_j = 175^{\circ}C$		60	80 <b>110</b>	mV
Discharge switch off-state leakage current	$V_{DISCH} = V_{DD}$ $T_j = 25^{\circ}C$ $T_j = 175^{\circ}C$		4	6 <b>80</b>	nA

<sup>1</sup> The timing accuracy, drift with temperature and supply voltage in monostable as in astable configurations are computed supposing passive components are error free and have no drift with temperature. Accuracy and drift values shown are due to the CMT-555 only.

<sup>2</sup> In the monostable configuration  $t_{pulse} = 1.1 R_a C$ . Assign the accuracy and drift errors to the "1.1" factor.

<sup>3</sup> In the astable configuration  $f_{oscill} = 1.44 / [(R_a + 2 R_b) C]$ . Assign the accuracy and drift errors to the "1.44" factor.

**Extended Functionality Characteristics**

Parameter	Condition	Min	Typ	Max	Units
Temperature sense					
Accuracy		750		790	mV
Linear Sensitivity	Between -55°C and 175°C	-1.69		-1.55	mV/°C
Sensitivity					
A	$V_{TEMP} = A + B T (^{\circ}C) + C T (^{\circ}C)^2$	745		789	mV
B		-1.63		-1.47	mV/°C
C		-433		-0.430	nV/°C <sup>2</sup>
Internal capacitors					
Initial accuracy		-17		+17	%
Voltage dependence					
VC1	$C(V) = C_0 (1 + VC1.V + VC2.V^2)$		-0.475		10 <sup>-3</sup> /V
VC2			-4.30		10 <sup>-6</sup> /V <sup>2</sup>
Temperature dependence					
TC1	$C(T) = C(T_0) [1 + TC1.(T-T_0) + TC2.(T-T_0)^2]$		0.023		10 <sup>-3</sup> /K
TC2			0.013		10 <sup>-6</sup> /K <sup>2</sup>

**AC Electrical Characteristics**

Unless otherwise stated:  $V_{DD} = 5V$ ,  $T_j = 25^{\circ}C$ . **Bold underlined** values indicate values over the whole temperature range ( $-55^{\circ}C < T_j < +175^{\circ}C$ ).

Parameter	Condition	Min	Typ	Max	Units
Maximum frequency in astable mode.			4.2		MHz
Output pulse rise time	$R_A = 1k$ to $1MEG\Omega$ , $C = 10nF$		2.2 <b><u>14</u></b>		ns
Output pulse fall time			<b><u>3</u></b> <b><u>14</u></b>		ns

## Typical Performance Characteristics

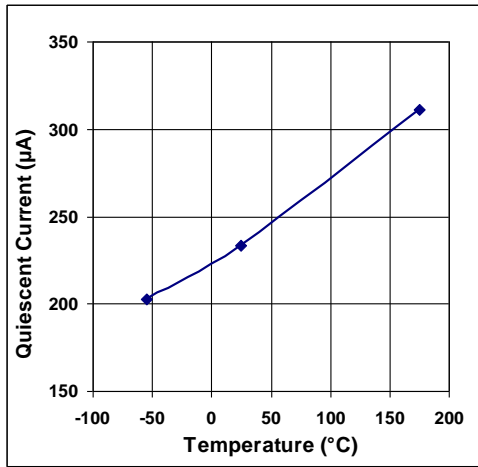

Current consumption,  $V_{DD} = 5V$

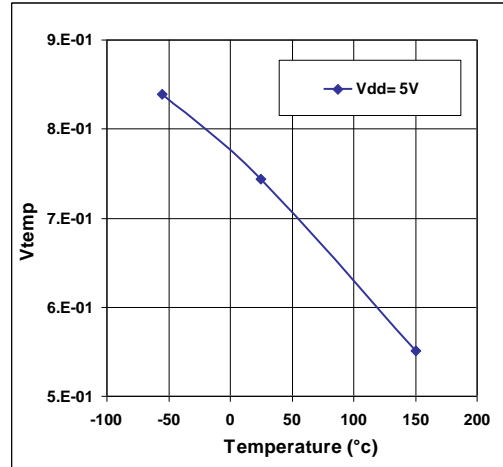

Vtemp,  $V_{DD} = 5V$

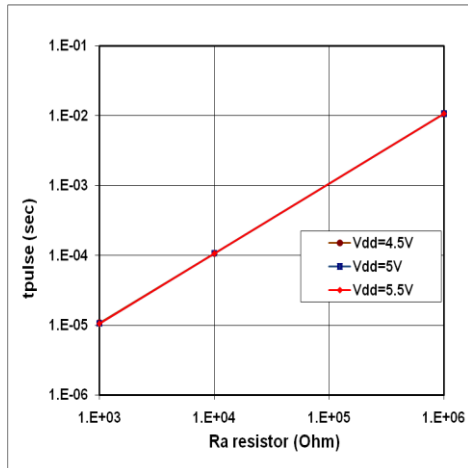

tpulse Vs Resistor in monostable mode,  $C=10nF$ ,  $V_{DD}=4.5$  to  $5.5V$

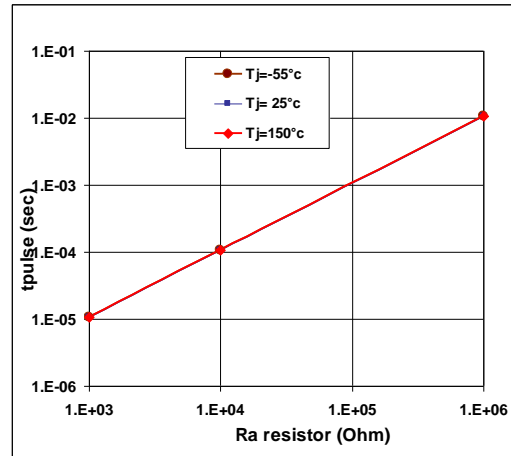

tpulse Vs Resistor in monostable mode,  $C=10nF$ ,  $T_j=-55$  to  $+150^\circ C$

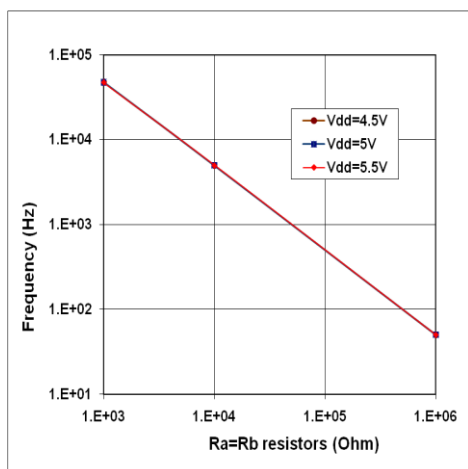

Frequency Vs Resistors in astable mode,  $C=10nF$ ,  $V_{DD}=4.5$  to  $5.5V$

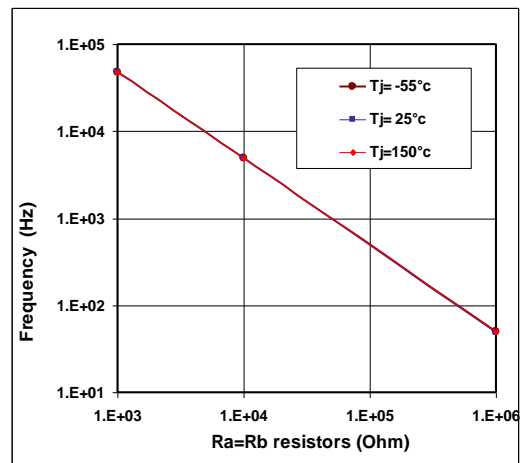

Frequency Vs Resistors in astable mode,  $C=10nF$ ,  $T_j=-55$  to  $+150^\circ C$

Typical Applications

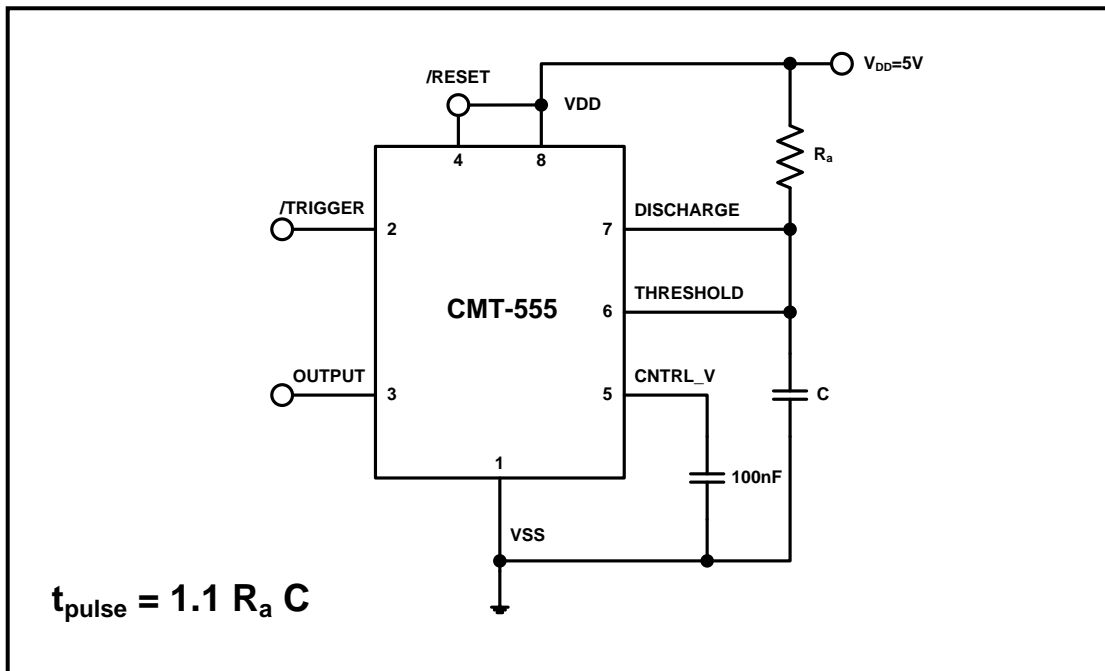

Figure 1. Monostable configuration.

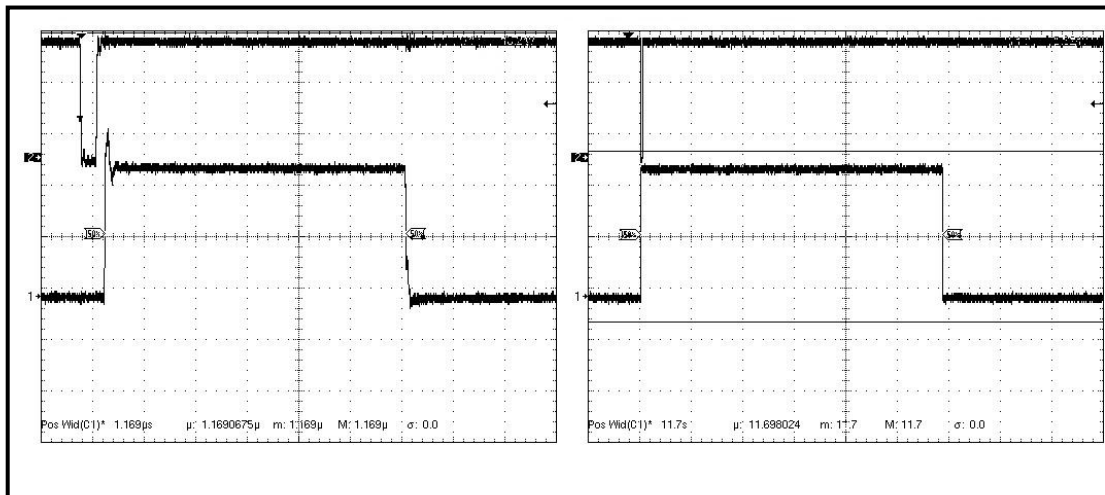

Figure 2. Monostable output waveforms: 1.17μsec (left) and 11.7sec (right).

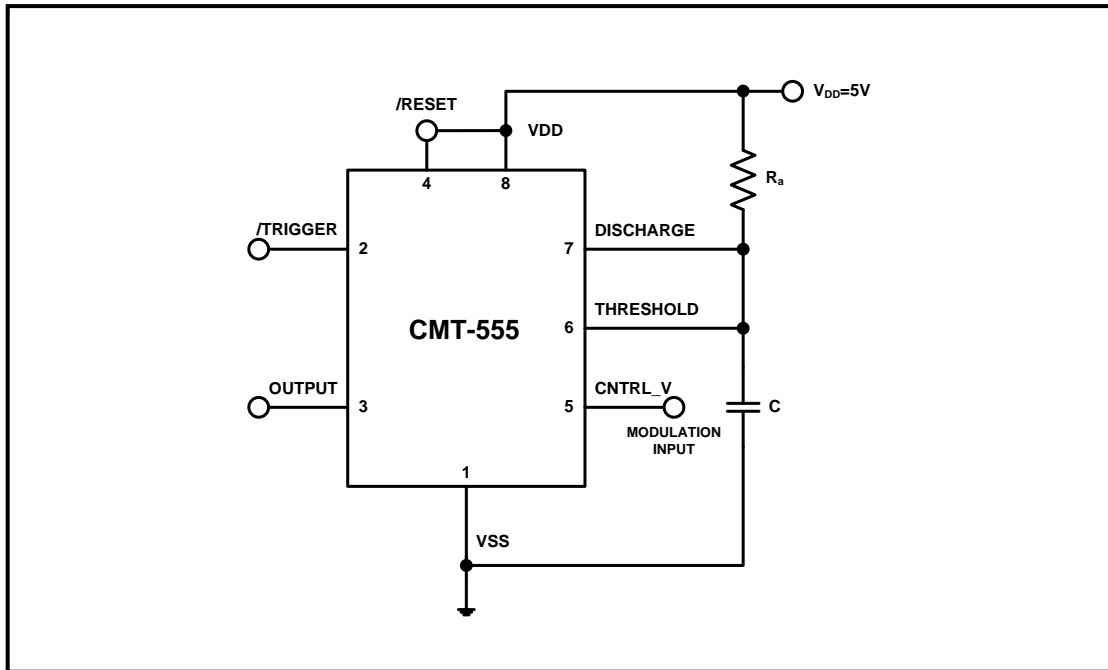

Figure 3. Pulse width modulator configuration.

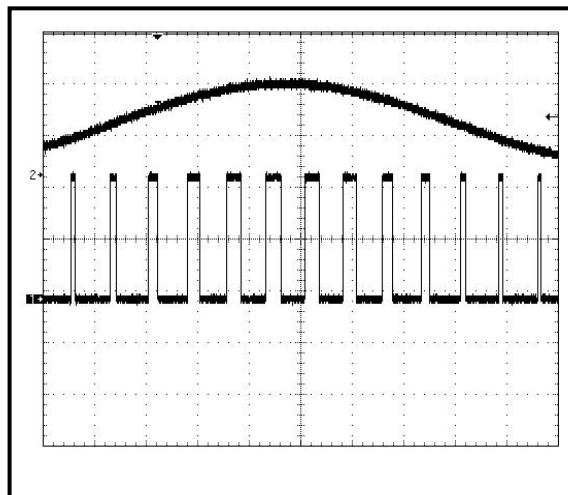

Figure 4. Pulse width modulator output waveforms: modulating signal (above) and output signal (below).

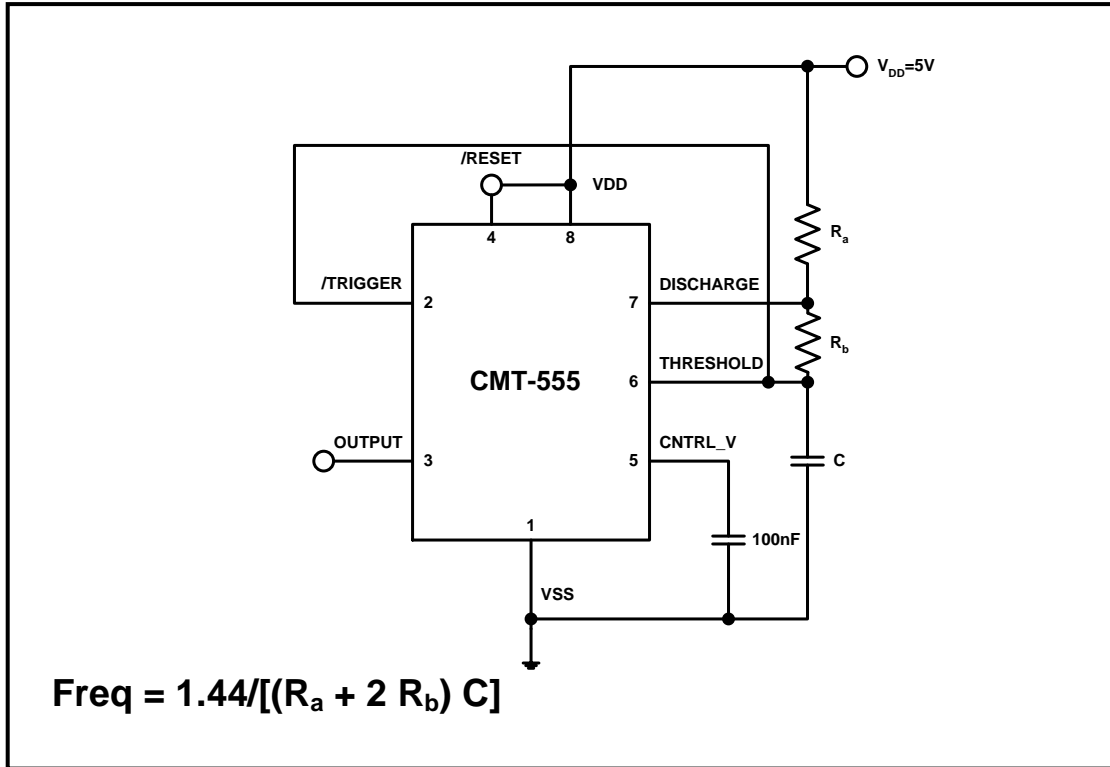

Figure 5. Astable configuration.

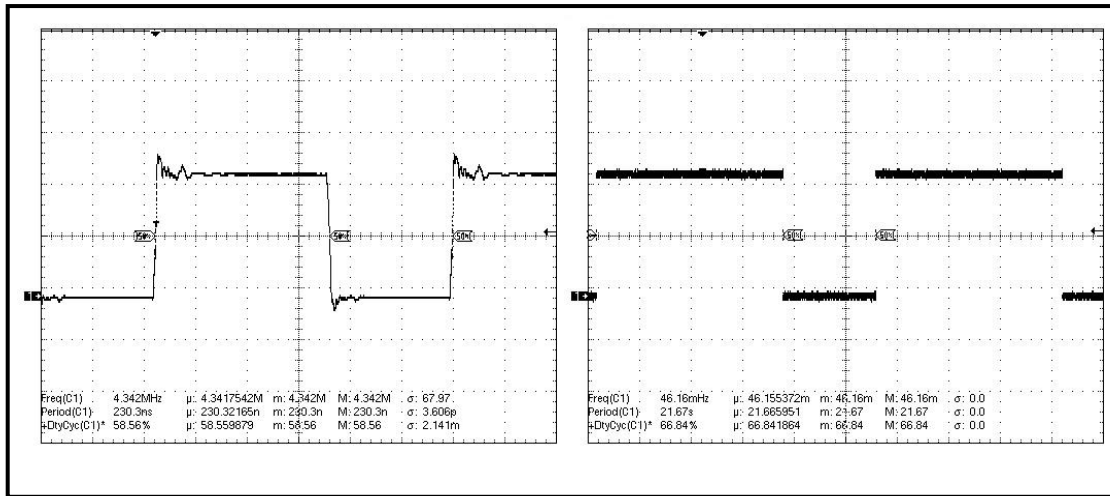

Figure 6. Astable output waveforms: 4.32MHz (left) and 46.2mHz (right).

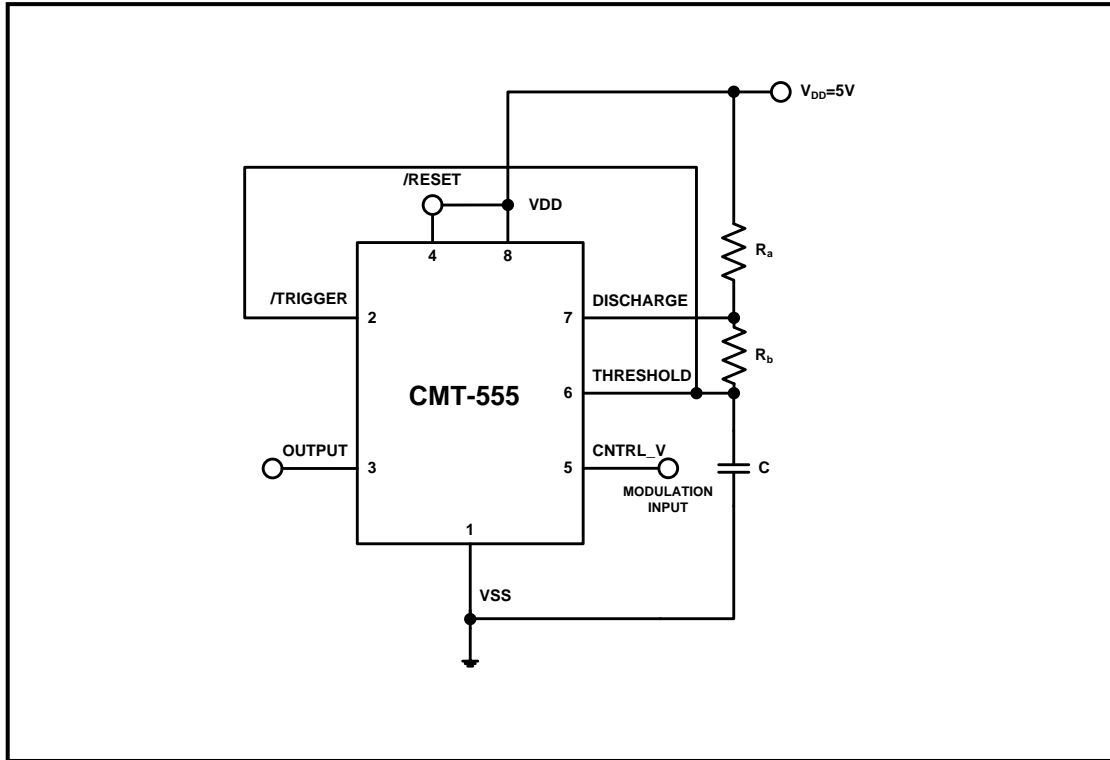

Figure 7. Pulse position modulator configuration.

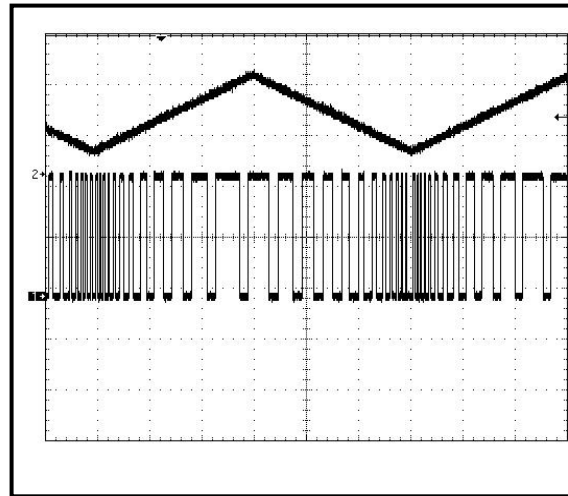
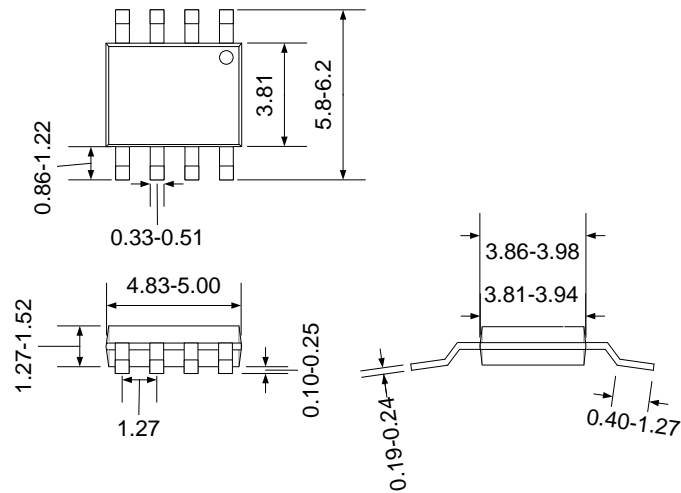

Figure 8. Pulse position modulator output waveforms: modulating signal (above) and output signal (below).

### Ordering Information

Ordering Reference	Package	Temperature Range	Marking
CMT-555-PSOIC8-T	Plastic SOIC8	-55°C to +175°C	CMT-555

## Package Dimensions



Drawing PSOIC8 (mm +/- 10%)

## Contact & Ordering

### CISSOID S.A.

<b>Headquarters and contact EMEA:</b>	CISSOID S.A. – Rue Francqui, 3 – 1435 Mont Saint Guibert - Belgium T : +32 10 48 92 10 - F: +32 10 88 98 75 Email: <a href="mailto:sales@cissoid.com">sales@cissoid.com</a>
<b>Sales Representatives:</b>	Visit our website: <a href="http://www.cissoid.com">http://www.cissoid.com</a>

## Disclaimer

Neither CISSOID, nor any of its directors, employees or affiliates make any representations or extend any warranties of any kind, either express or implied, including but not limited to warranties of merchantability, fitness for a particular purpose, and the absence of latent or other defects, whether or not discoverable. In no event shall CISSOID, its directors, employees and affiliates be liable for direct, indirect, special, incidental or consequential damages of any kind arising out of the use of its circuits and their documentation, even if they have been advised of the possibility of such a damage. The circuits are provided "as is". CISSOID has no obligation to provide maintenance, support, updates, or modifications.